

SECRETS OF VERMIN

The manual for brave people who want to understand why vermin is important not only at Ostrovné lúky, but also in their ordinary life.



SECRETS OF VERMIN

Authors: Katka Béresová, Ladislav Bíro,
Ladislav Vojtuš

Center of Environmental Education
Dropie
2021

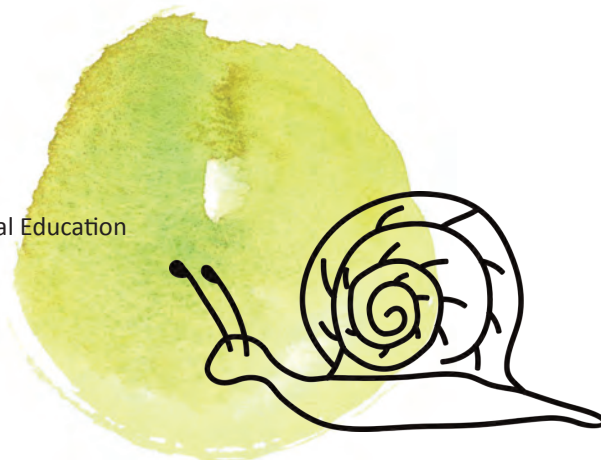

Thanks to our friends and friends of our friends.

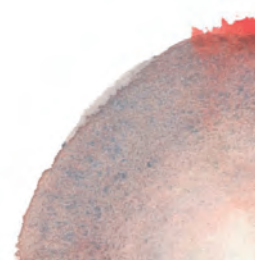

"The fact is that no species has ever had such wholesale control over everything on earth as we now have.

That lays upon us, whether we like it or not, an awesome responsibility.

In our hands now lies not only our own future, but that of all other living creatures with whom we share the earth."

David Attenborough



What is vermin?

According to the Slovak Language Vocabulary, the word “vermin” is the plurale tantum of the feminine gender and it means:

1. pejoratively: good-for-nothing, villains, riff-raff: “Yes, you are vermin. Only Kúrňava knows what is the duty.”
(*M. Urban*)
2. expressively: animals (usually small, often about insect)“ „... swarming small vermin in water...”
(*Ľ. Zúbek*)
3. figuratively: about children: “See, this vermin has been annoying me since the noon.”
(*B. S. Timrava*)

Vermin usually have unpleasant, bothering, useless and disgusting effect on us. However, cannot be such vermin also interesting with something? What secret does it have? Does it have many legs, eyes, it is hairy, slimy, or completely bald? Where does such vermin live? And what does it eat? And can such vermin be good for anything at all?

The manual “Secrets of vermin” aims to introduce in more detail the most common species of small animals and their huge importance for nature. At the same time, it endeavours to motivate positively for efforts to attract vermin just to the school premises and watch how it lives there. We hope that with the help of our advice and instructions you will experience a lot of nice, interesting and advantageous moments when learning secrets of vermin.





We will try the game About "the most ugliest" vermin.

 We need large sheets of paper according to the number of groups, graphic aids (colours, India ink, brushes, black leads, pencils, glue,...), crepe paper, various waste materials, there are not limitations for fantasy;

 We divide children into groups of max. 5 members, we can use Symbols dividing activity (according to the number of children and groups, we prepare various symbols for labels and stick them on children's foreheads so that they cannot see them, and their task will be grouping correctly according to symbols; when doing so, they are not allowed to talk, show symbols to each other with their hands, look at their pictures on mobiles or at mirrors...);

 The task of the groups is to think up the ugliest, most disgusting and most unpleasant vermin and materialize it on paper by means of graphic aids, waste or natural materials (we follow the ethical rules when collecting natural materials – no live animals are allowed to use or excessive destroying of plants is forbidden);

 It is necessary to describe the originated vermin – to make up its genus and generic names, describe in detail where it lives and what it eats;

 Each group will present its vermin to the others. What feelings do these new species of vermin evoke in us? Do works created impact on us in a more unpleasant way or what we hear about it – what does it eat and where does it live?)



Special Protection Area Ostrovné lúky

The Special Protection Area Ostrovné lúky is a flat region of the western Slovak lowlands surrounded by the three rivers – Dunabe, Váh, and Small Dunabe. The character of the landscape was formed in the past just by activities of these water courses. Local people used many specific terms identifying a specific type of wetland, bank and deposits of rivers, water area. At present, we cannot find such water biotypes in this territory any more. Several remnants of the dead arms of the rivers of Čalovecký Dudváh and Částa have only left here. Sometimes in the past, the landscape was full of various vermin.

In the region of Ostrovné lúky we can find mainly large fields, agricultural land account for nearly 95% of the area. Here and there we can find small islands of regularly scythed grass biotopes, remnants of forests and growths of willow trees. In the past, the landscape was made up by a network of agricultural farmsteads - „tane“ and large pastures. At present, only very few original biotopes have still have been preserved, thanks to which many more species of birds lived in the landscape in the past.

The opened lowland area of the Special Protection Area Ostrovné lúky (8,729 hectares) is one of the most precious biotopes for the appearance and nesting of red-footed falcon (*Falco vespertinus*). The agrarian type of the landscape with scattered groves, ridges and pastures also suits lesser grey shrike (*Lanius minor*) and tawny pipit (*Anthus campestris*).

The aim of the project LIFE12 NAT/SK/001155 Protection of birds in the Special Protection Area Ostrovné lúky is to contribute to the active protection of biotopes of birds of the European importance in the agricultural landscape by renewal of nesting and food



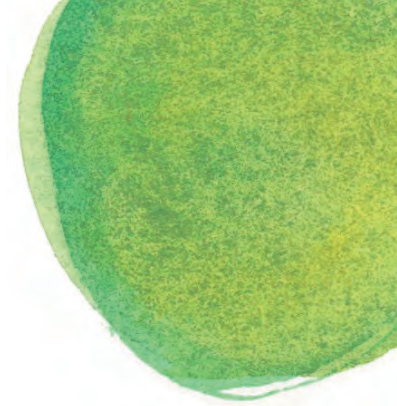

biotopes of target species; and to increase the variety of the landscape mosaic of the Special Protection Area Ostrovné lúky.

The renewal of permanent grass growths and pastures has been planned for the total area of 90 hectares; 17 km of bio corridors will be revitalized in the form of groves, windbreaks, alleys, ridges, field paths, and their edges.

At Ostrovné lúky, 500 old head willows will be cut off and 500 new ones will be planted. Fifty wetlands will be renewed in suitable places. Wetlands are important places for insect that is used as food for birds. Nest and half-nest boxes will improve nesting possibilities for birds. Elevated hunting tree stands, groups of boulders and wooden small columns will be placed near renewed grass growths. Birds use them for hunting, guarding and marking their territories by singing.

The important target of the project is also education, enlightenment, and increasing awareness about key subjects and the public about the nature and landscape protection.



it does not build its own nests. And rooks are gradually moving to places where red-footed falcon does not follow them.

Red-footed falcon

(*Falco vespertinus*)

Red-footed falcon (*Falco vespertinus*) is a very small species of falcon. It is the most colourful falcon.

It seeks for an open lowland landscape with a thin alley and groups of trees and with a sufficient quantity of big species of insect making up the basic component of its food. In any years poorer in insect, however, it can also enjoy eating frogs.

16 years ago (2000), 60 – 80 pairs were nesting in our country. Disappearing of red-footed falcon is also connected, in addition to more and more intensive use of chemicals on fields and liquidation of the last groves and growths in the rural landscape, to the fate of black rook. This bird is connected to rook nesting colonies, as



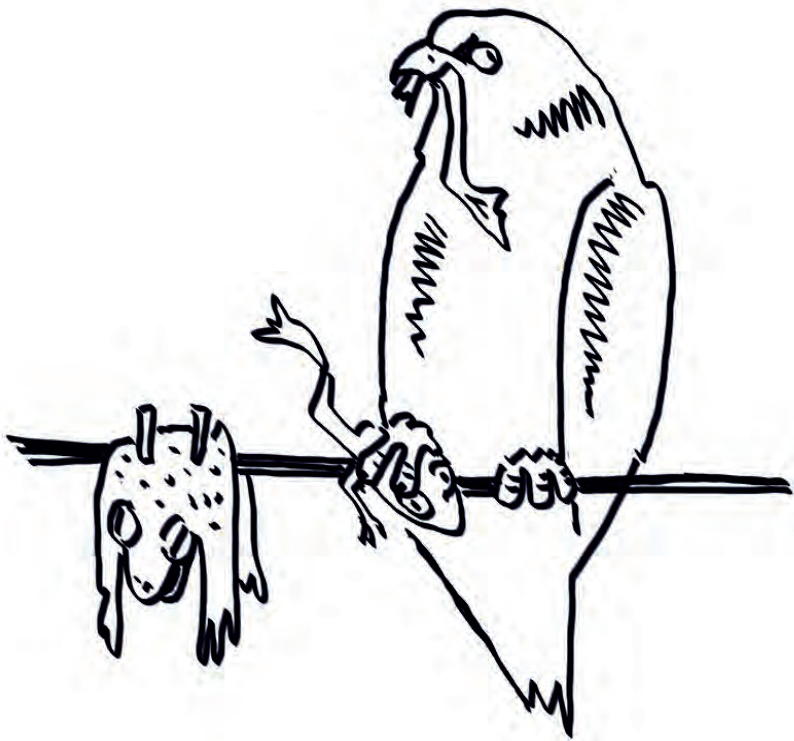

Tawny pipit

(*Anthus campestris*)

It is a discreet brown-coloured bird. It inhabits steppe biotopes, dry sand and stony areas, edges of fields, meadows, roads with relatively low and sparse vegetation. The male often sings during its step-wavy flight. They move quickly on the ground, while they often straighten up when stopping. They like using various elevated places - ridges, stony monoliths, heaps of stones, small columns for guarding. Their nests are placed on the ground. Tawny pipit feed on various small invertebrates that it picks up from the ground.

This species is endangered mainly by agricultural work, disappearing of places suitable for nesting, and a decrease in insect as food due to chemicalization.





Lesser grey shrike

(Lanius minor)

In Europe, it is mainly linked to areas with intensive land cultivation. Originally, it is a kind of dry grass biotopes, inhabiting the open landscape mainly at lowlands.

A rapid decrease in their number in the 20th century is connected with the intensification of agriculture and the related changes in the open landscape. The typical nesting biotope of lesser grey shrike in the Special Protection Area Ostrovné lúky includes high poplar alleys and groves or smaller forests formed mainly by locust tree. They build their nests relatively high (on average 8 metres above the ground). Under the ideal

conditions, this species creates open nesting colonies.

They feed on large species of insect – crickets, grasshoppers, or beetles. Shrikes are the most predatory singers. They are known for their ability to create reserves of insect. They impale it on thorns or also barbed wire, and they are able to return to it later.





LESSER GREY SHRIKE 'S „KEBAB“



Amiable landscape

The landscape of the **Lower Rye Island** has been formed over thousands of years not only by waters of the rivers of Danube and Váh. The important task was also played here by the courses of the rivers of Částa and Čalovecký Dudváh, today already not existing. As late as at the end of the 19th century, meadows and pastures accounted for more than 30% of the cadastre. Beef cattle, horses, and pigs were mainly grazing here.

The individual homesteads - „*tane*“, often even kilometres far away from each other, together with their fruit orchards, mixed with growths of head willows, meadows and pastures, created the typical character of the southern region. Long hot summer and sophisticated system of irrigation ditches, were used by farmers for growing excellent apricots. Small fields were connected

by the complicated network of ridges or field paths. The endless horizon of the cane sea was completed at sunsets with the seesaw wells that looked like huge herons. Such landscape ensured living for people, but at the same time many, today already precious species of plants and animals, could also be found here.





Unpleasant landscape

The landscape is the picture of a man. After the flooding in 1965, people have changed the picture of the Ostrovné lúky landscape definitely. By the decision of authorities, agricultural farmsteads – „tane“ disappeared that created a beautiful and unique mosaic of the lowland landscape. In 2015, the arable land accounted for nearly 95%, water and built-up areas for nearly 2% of the area and the rest was made up by forest areas, permanent grass growths with other areas, gardens, and orchards. We have dried and ploughed in wetlands which were the living space for many species of insect, water birds, and other animals. We have gained the dominance over vast fields.

We ploughed in ridges and pastures that were a shelter not only for the king of lowlands – bustard, but also for many other species. We cultivate fields using huge machines that compact soil. From among spikes of wheat we have forced out common cornflower and cockle. We have achieved nearly a sterile area without life. We can kill off everything we do not like. We have interconnected places with power lines on high poles, where many birds find their death.

Until when will nature have patience with us?

What are we able to do with it?



Let us plant trees and small bushes everywhere possible;



Let us create suitable shelters for vermin;



Let us make nest boxes, boxes for hedgehogs, and bats;



Let us plant melliferous flowers;



Let us try to hold water in the landscape;



Let us get to know the fragile network of relations and let us tell the others about it as well.





What with it now?

If we want to achieve some result – positive change, we should start from ourselves and try it with gradual small steps in our surroundings. Let us try to attract various vermin to school premises and by means of it even more species of birds and any other interesting animals. Achieving a change means to make the following four simple steps:

1. let us map before a change;
2. let us propose the plan of changes;
3. consult our intentions with the school management, let us seek advice from experts;
4. implement changes and watch what will happen.

In order to get to know the mutual interconnection of various species of plants, animals, and biotopes

at Ostrovné lúky, we can play the game **Cobweb of island relations**.

We will need the following:

 A ball of cord, small cards and children grouped into a circle (the best is when we play on grass);

 Small cards on which we write components of ecosystems (some can also be provided more times: soil, water, air, grass, cane, cow, female mosquito, frog, stork, Africa, wetland, frog, beetle, wasp, vermin, earthworm, tawny pipit, dragonflies, shrikes, grasshoppers, more crickets, red-footed falcon, locust tree, hazel, garden etc.).

Children are standing or sitting in a circle. The first child who has a cow on his/her card catches the ball and throws it to the mosquito with the explanation that it drinks its blood. The player with the card of mosquito throws the ball to the “wetland” because it lays eggs there. We are looking for connections until a cobweb of relations is created. The game continues until each child has been involved or until the ball is completely used. What happens if, for example, wetland disappears from the cobweb?





Let us map before a change

 we ask the school management for map documents, we obtain orthophotomap that we can redraw through tracing paper; we prepare map documents at the informatics lesson, we use squared paper;

 we mark in the map the following borderlines of the school premises, buildings, pavements, water areas, sports grounds, areas suitable for "change", any other areas and green vegetation;

 we mark greenery with clear symbol for trees, small bushes, garden beds, gardens, fruit orchard, compost side, wild corners (it is good to have trees counted up, divided into deciduous and coniferous ones, domestic and exotic ones, whether they bring some benefit, we determine species of a tree, small bush, or herb by means of the key or expert);

 if we have already various boxes, insect hotels - places where vermin lives in the school premises - we mark everything with clear symbols;

 we mark the orientation towards the cardinal points in the corner of the map;

 we calculate the total area of the premises in m^2 (we can also convert the area into ares - 1 are = 100 m^2 , i.e. the unit of area used in agriculture), we determine the percentage representation and the share of grass and reinforced areas, areas with clearly defined use (sports grounds, car parks, pavements...), we determine the percentage of the area where we can make changes that will attract vermin;

 we count up how many species of birds live in the school premises; do not be afraid, it is not always necessary to determine exactly a particular species, the resulting number of species in the period without nesting, winter and nesting periods is more important and, of course, their total summary per year.



Let us propose the plan of changes

We can attract vermin to the school premises by creating a colourful mosaic of food and shelter possibilities. According to the results of our mapping we already know what we are missing in our premises.

There is an example of places that have the biggest success among vermin:

 various types of insect hotels and shelters, lushly overgrown, not scythed corners, heaps of stones and branches;

 garden beds of melliferous flowers, planting on fruit and other trees or bushes;

 boxes for birds, bats, and hedgehogs;

 small water bodies and wetlands.

Let us consult our intentions with the school management, seek advice from experts

We already know what and where we would like to have in order to attract as many species of vermin as possible. However, we should not forget the following principles:

 let us consult our final plan with experts (they will certainly help you at the Environmental Education Centre (SEV) of the Slovak Environment Agency (SAŽP) Dropie);

 let us ask for the approval with the implementation from the school management – let us ask for their opinion, comments and assistance, support and directing, while respecting consistently the utility services and their protective zones (gas, water, electricity, optical networks,...);

 let us get involved in the school caretaker's and cleaning lady's work, in particular in the case of placing boxes and insect hotels, let us include comments in the final plan and think over the care of planting at the time of school holiday (in particular watering!);

 let us inform teachers, pupils and their parents of planned changes, let us involve as many people as possible.



Let us implement changes and watch what will happen

We have the final plan completed for the implementation of changes, therefore we can start with them. However, how can we find out whether our changes were successful and useful? With the work on increasing comfort for all kinds of vermin we are improving our ability to work in a team, use various tools, we get to know flora and fauna around ourselves and fragile links connecting them.

We will be certainly pleased if our insect hotel will really be full of various insect. In the small house for bats a summer colony of red bats settles, and we will admire butterflies sucking nectar in a planted garden bed. After making the changes, we will again count up birds in the school premises. We can watch the bird population every year. The results may surprise us and will force us to think over things from another angle of view.





Before we start...

At the beginning, in the spirit of the classic – writer, singer and musician Braño Jobus "*Safety at work is sometimes more important than work itself,*" we check and present the following tools before the implementation:

 we will use hammer, pliers, small saws, screwdrivers, nails;

we always take care so that tools are in the perfect condition and we use them only for its specified purpose;

 when working, we deposit tools in a safe place so that they cannot fall, so that we cannot stumble over them, etc.;

 when sawing, we hold the saw with both hands, while the item we are sawing must be firmly fixed;

 we inform children what to do in case of injury.

Vermin house

Once insect or any vermin had enough shelter possibilities and the place where it could build their nests or create nesting small chambers. Houses were built of natural materials and roofs were covered with reed or shingle.





However, now many buildings have thick layers of polystyrene. It protects from a loss of heat, but vermin does not like it as it alternative home. Maybe only with the exception of woodpecker. We can see more and more often colourful rubberized metal plates or asphalt singles on roofs. In such environment, our vermin has no chance.

Therefore, we have decided to teach you how we can build together "vermin house" – insect small house at a garden or school courtyard. It can be a more complicated palette vermin house, a wooden box filled



with various natural materials, but an upturned clay pot in which a rag is affixed can be sufficient.

What will we need for building a **palette vermin house**?

-  3 - 5 pieces of palettes – according to their height; we use one for the roof;
-  Wire netting for the protection against birds;
-  8 pieces of bricks on which we lay the palettes, 28 pieces of tiles and 4 ridges we use for the roof;
-  A large quantity of natural materials (leaves, hay, cane mats, cones, pieces of bark, hollow stems, elder small branches, straw, wool,...) and various waste materials (old rags, cans, hoses,...), unfired or leaky bricks, drilled wooden logs (the hole diameter of 2 – 10 mm), small plant pots with melliferous flowers;



First, we select a suitable place for the vermin house. A less frequented place at lee side is perfectly suitable, with direct fall of the sunlight. We lay palettes on bricks the middle part of which we fill at the same time. In order to achieve their stability, we connect palettes with nails or wire. We fill the vermin house with various materials. We prefer natural materials that can decay in nature over time. We affix wire netting on palettes from outside so that the vermin house does not change to only a large feeder for insect-eating animals.

When building a shelter, we have to saw up one palette into halves and affix both its parts to each other in the form of roof shield. Let us ask for help the school caretaker or a skilful parent. We lay shingles on the roof made of palette to prevent raining into the vermin house.

We can decorate the vermin house with small plant pots (e.g. yoghurt cups) with planted melliferous flowers. Let us select species that will endure over drying well - thyme, marjoram... We provide a room with breakfast for occupants.

Mini vermin houses

In addition to a large palette vermin house, we can also produce many other types of insect hotels. A very simple solution is an old tall can or PET bottle with a cut off neck. We fill them with remnants (at least 10 - 15 cm long) of cane mat twisted into a roll. The can or PET bottle should exceed the cane mat to protect it from rain. We place this mini vermin house on a protected sun wall.

For vermin houses, we can use old boxes, drawers, cases, but also simple wooden lathes.

Plant pot for earwigs

We need a smaller clay plant pot, cord, old rags or straw and hay. We can decorate and paint the pot. We place an old rag or straw inside it so that its edges do not protrude outside and that it does not rain on them. We hang the pot in the tree crown so that its edges touch a branch so that earwigs can comfortably get into it. Even if earwigs can fly, they prefer crawling into the small house. They feed on dead parts of plants, but also small animals, mainly small louses.

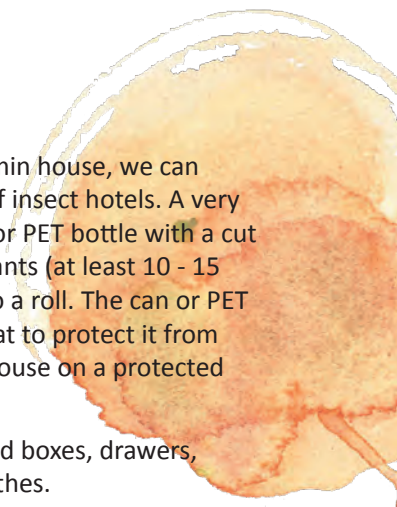



Nesting box for birds

The eternal life cycle and the relation food vs. hunter are the basic driving motor for the community functioning in a specific place.

Yes, your school courtyard is also the scene of this fascinating theatre. However, the director is not a man, but the omnipotent Mother Nature. Many species of birds have lost their nesting possibilities in a changed landscape. In addition to tits, redstarts or flycatchers for which we build classic boxes, a person can also help, for example, long-eared owl by making half-nest boxes or hanging the nesting pad for various species of falcons. In the past, small falcons occupied abandoned nests of rooks; tits nested in cavities of old trees and various species of owls had their nests in lofts of farming buildings.

However, such places are gradually disappearing, and if we want to enjoy twittering of feathered animals while walking at the school garden, let us start working now!

 We need not planed off, sufficiently thick boards, at least 2.5 cm, so that young birds could be able to climb its walls out for their first flight.

 We never place a perch in front of the fly-into hole (it would facilitate predators, for example martens, to get into the box).

 Let us not forget that it should be possible to open the small roof of the box so that we are able to clean after the season, and at the same time it should be covered with a waterproof layer (roofing materials made of Tetra Pack packages proved to be very effective for us).

 The box bottom must be embedded among walls and properly nailed, birds do not like draught therefore we take care so that walls fit tightly.

 When the box is ready, we can paint it with acryl colours, and thus make the box attractive not only for small birds, but also for the school visitors.

 We place the box in a suitable biotope in autumn, at a certain height, with a slight inclination forward (flowing down of water) on a wooden or metal lath. The front side of the box should be directed to south-east (we do not place it in a dense growth and it has to be affixed firmly so that it does not sway in wind).



If we are nailing the box on a lath with nails into a tree, we do not hammer the nail up to its head, but we leave a sufficient space for the tree growth (we place boxes on older trees that endure nailing better).



We start noticing according to which new occupants select their homes. Information being monitored also includes the height of the placement above the ground, species of a tree where the box is hung, or the orientation towards the cardinal points. Occupants reward us not only with their singing, but also catching flies, mosquitoes, or another vermin.

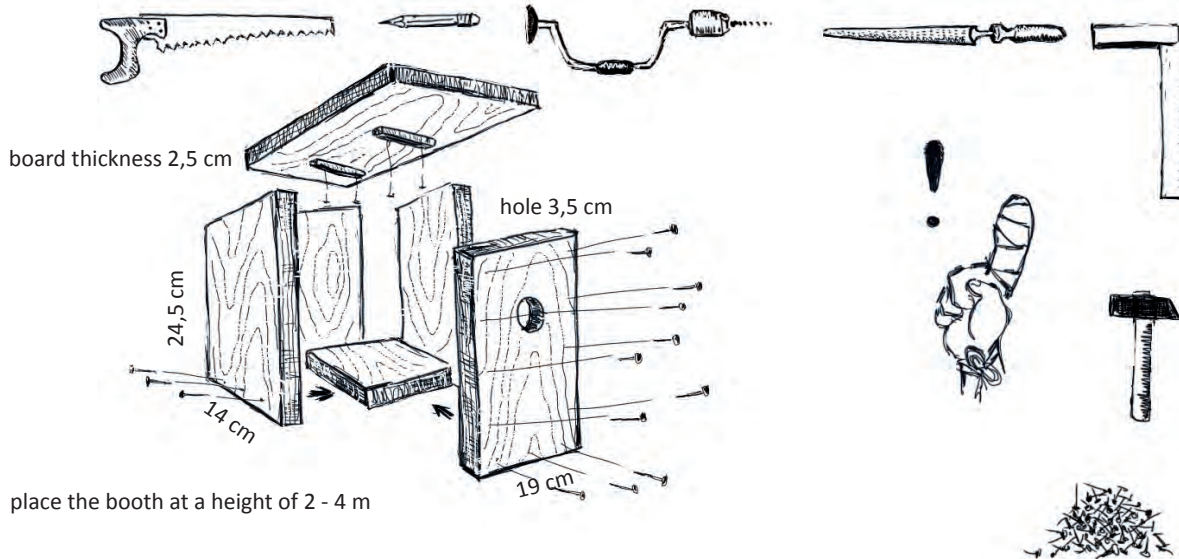



Feeders and watering places for birds

Winter is an ideal period for producing feeders for birds. We feed birds with the most varied food – sunflower, powdery mixtures, fat, raisins, rolled oats, or nuts. We do not feed them with salty and smoked food, bread, boiled potatoes, remnants of cakes, or rotten and/or otherwise deteriorated food.

Tips for feeders:

 We place the feeder minimally two metres from glass areas in a calm place with a good view and we clean it regularly (the shelter of the feeder should exceed so that it does not rain and snow on feed materials).

 Various small nettings of food (oranges, garlic) have proved successful most, filled with little seeds and fat where droppings do not stick, unlike classic feeders.

 We can also use waste materials for the production of feeders.

 This is a simple tip for **bird delicacies** – fat cups and stuck seeds. We need fat (that does not melt easily, e.g. Palmarin) and a mixture of small seeds for birds.

We need paper cake cups for fat cups. We fill cups with a mixture for birds, pour over with melted fat and stick a straw in each cup. We stick cups into pots. We cut off various forms out of old cardboard – small stars, birds, small hearts, and we attach a wooden skewer. We pour each cardboard form with melted fat (tougher is better, just before dissolving) and sprinkle with seeds, and we let it become stiff in a refrigerator. And we have stuck seeds for birds ready.

 We are also able to help birds in winter by planting suitable species of plants that can be used as their food – elder tree, hawthorn, maple, honeysuckle, birdseed; out of herbs: nettle, teasel, thistle, St John's wort, mullein, and many others. Let us take it into consideration when planning of planting.

Let us not forget watering places either. There is a big choice of various watering places made of various materials available in shops. However, a big shallow bowl or a small bowl under pots can also be used. We place watering places in the open space and put stones or a board in the middle where they stand when drinking.

Boxes for bats

In addition to the thermal insulation of school buildings, we are losing the possibility to co-exist with another fantastic animal species, i.e. bat. Various legends and scary stories have made bloodthirsty creatures from them. However, our Slovak bats are small animals quite harmless for men. When reducing the number of night insect they even play an irreplaceable task! It was not a chance that this only flying mammal has become a model of the popular comics about Batman.

And let us try to help it with our joined forces so that it can live together with us.

 We need 2.5 cm thick, not planed off boards.

 A slot serving as a fly-into hole situated in the lower part of the box, 2.5 – 4 cm wide, provides the perfect comfort for most bats living in Slovakia.

 We select a place carefully where we install the box for bats. It should be at a height of minimally three metres above the ground, preferably at the western side (you certainly know that bat droppings are a very valuable fertilizer – professionally called *guano* that

you can use later for fertilization of the school garden; however, if we place the box above the entrance to the school, the cleaning lady would not definitely praise us).

 Bats need perfect darkness for their calm daily sleeping, therefore let us take care of perfect sealing of slots of the box (the bat's favourite colour is black or brown – so let bats have it, maybe with a few yellow or red details or the reference for passers-by: "*Bat-Man lives here – please do not disturb*").



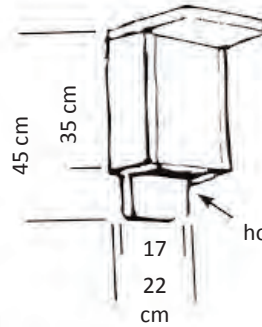
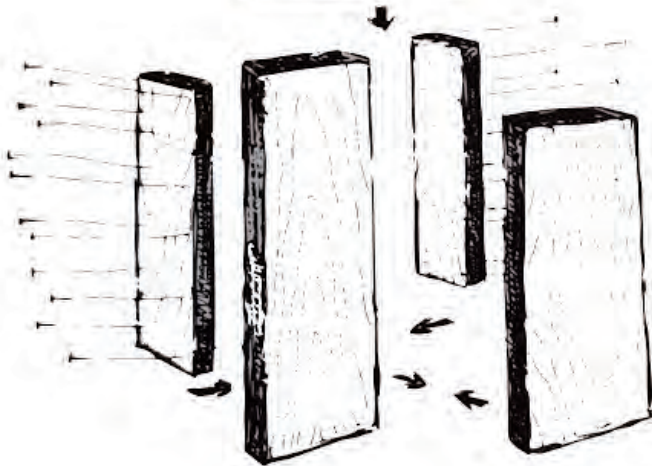
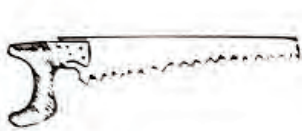

board thickness 2,5 cm

hole width 4 cm

17
22
cm



Herb and perennial garden beds

"What a wonderful smell! And that taste...", you say to yourselves when tasting mint lemonade with brown sugar and a slice of lemon in hot weather.

Or winter drinking tea made of thyme while watching birds in a feeder behind the window of the classroom a few days before Christmas.

Garden beds please not only us, people, but their flowers are a source of sweet and nutritious nectar for a large number of species of butterflies, bees, or any other pollinators. If we want to attract butterflies into the garden, let us not forget plant plants for their caterpillars (e.g. caterpillars of swallowtails love plants from the carrot family, caterpillars of tortoiseshell love nettle).

The procedure for establishing garden beds:

 We mark the area upon which we have agreed with the school management and calculate the number of necessary plants, while taking into consideration the placement of the garden bed also in terms of the availability of water for watering.

 We remove "weed" from soil first and aerate it well; perennial plants appreciate adding of mature compost; we add no compost to herbs.

 For establishing a garden bed, the most important factor is the sun light – according to its intensity we have to select shade-intolerant (thyme, lavender, balm, monarda, coneflower, clove, daylily, ox-eye-daisy, coneflower, sage) or shade-loving species of plants (mint, violet, ramson, phloxes, hosta, meadowsweet, columbine); if we want to have both, a herbal spiral can be a more laborious alternative.

 In order not to have to purchase all plants, we declare "flower charity", it means that everybody brings excessive plant offsets or seedlings from their garden.

 We arrange plants on the garden bed – we place taller plants in the rear part and lower plants in the front part; we dig out a small hole, pour it with water, put a plant and earth it up well. We pour it repeatedly. Pouring is very important mainly after planting and in summer, at the holiday time. As early as during the school year we agree upon the system of duties; otherwise, an unpleasant surprise would wait for us in September.





Let us take care of invasive and potentially invasive plants (American asters, goldenrods, and others), we can mark planted plants with simple

nameplates (for example, names on ice lolly sticks, on broken pots...). Let us avoid poisonous plants, in particular their poisonous berries, such as yew tree, ivy, spindle-tree, henbane, eggplant, lily of the valley.

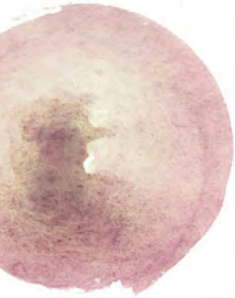

WILD THYME

SAGE

PEPPERMINT

LEMON BALM

LAVENDER





Plant trees

Is there any tree in your surroundings – at school, municipality and areas between municipalities? Such a real giant, titan? With such a huge crown and trunk circumference that two people cannot embrace it? Do you know its story? Do you know who and why has planted it? How old could it be, what species is it? Do you have any hedge not cut in your surroundings? There is still something nearby in every town or village!

However, there are never enough woody plants. If the conditions allow us so, let us try to plant together as many woody plants and bushes as possible – whether at school, municipality, at home, or in areas between municipalities. *Ostrovné lúky* need trees.

 At significant opportunities or in significant places, long-lived species were planted in the past. In our conditions, they were lime trees, oaks or also fruit species, such as pears or service-tree. When planning planting, we have to take care to have a sufficient space. Such lime tree can live to be even 1,000 years old! Therefore, it is necessary to consider the possibilities of the school premises.

 When planting, we always have to get the approval of the land owner. Let us find out whether there is, by chance, any electric wiring above the place where we want to plant a tree. We should also know what is under the ground. Distribution systems for water, gas or sewerage systems could be violated by roots later.

 Trees need to be planted in a sufficient distance from buildings, masonry foundations. It is generally said that the diameter of the crown above the ground equals to the diameter of roots under the ground. Can you imagine it?

 Let us dig out a pit sufficiently large for roots with attached soil. We pour the pit with water. We can treat the root system of trees with symbiotic and hygroscopic agents.

 Let us plant fruit trees. We may be lucky and get a typical local variety.

 Let us plant willows. Let us try to grow our own head willow.



How to do it

We need a cut off ticker branch from willow; the diameter of about 10 – 15 cm, length of about 2.5 m. We dig out a pit minimally 50 cm deep and pour it with water. We plant a willow branch. In the period after planting we water abundantly. In the first years, willow will give off side shoots intensively – we have to remove

them thoroughly. The head can already be cut off in the first year, thus we support the growth of roots. Later, the head is cut off on average once per five years on average.



When planting small bushes, let us select edible species also providing pleasure for taste buds – dogwood, hazel tree, honeysuckle, currant bushes or raspberry.

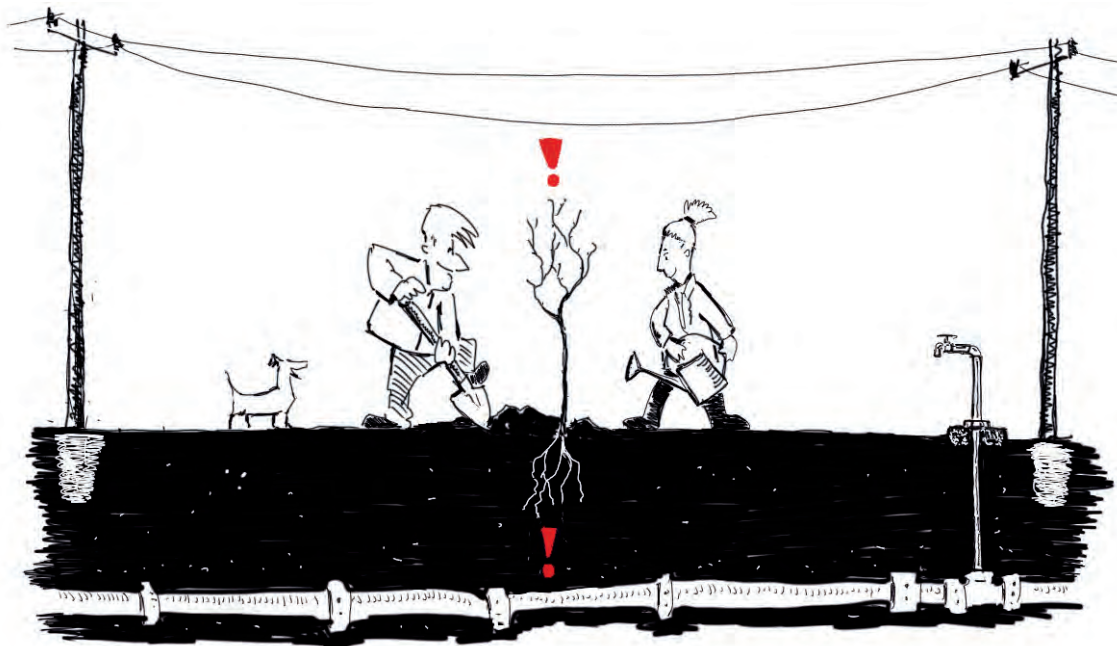

Please, familiarize yourselves...

Now we can focus on vermin, which we can acquaintance mostly. On previous pages we discovered, how can we arrange a space for living for them, in our gardens and school yards.

Just now it is the time, when we can "check their teeth" so to say. We are going to find out, what is the specification of mentioned species, how they are adapted for a survival conditions and how they can serve us.

From one side it is going to be an anthropocentric point of view, but we do believe, that we can understand a deeper meaning of all organisms and mutual relationships around us.

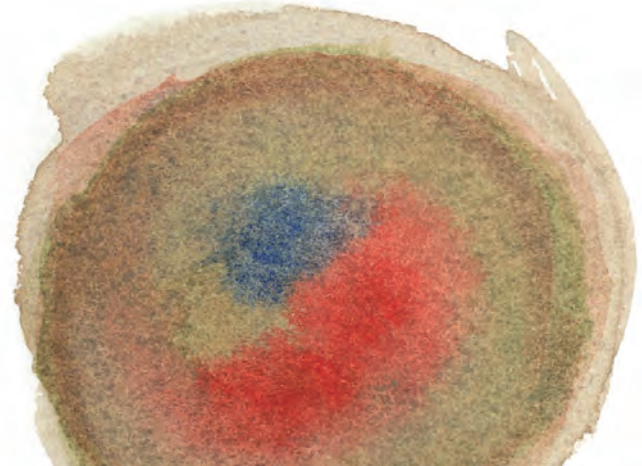

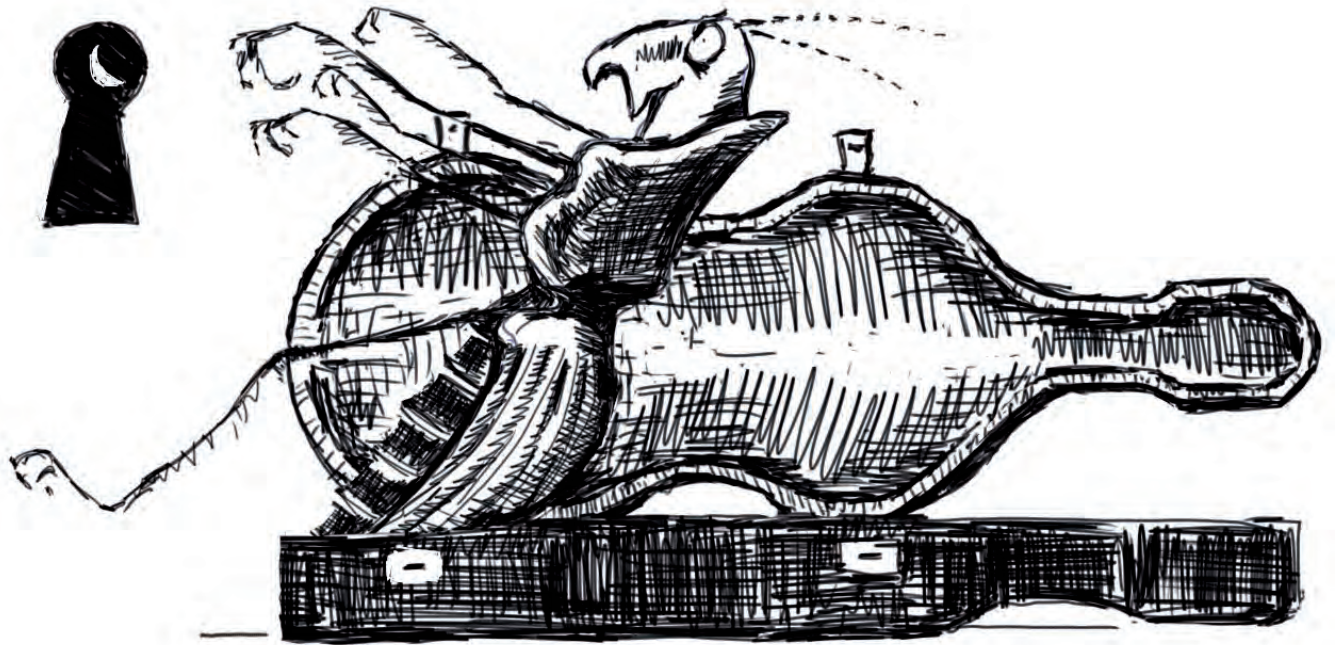

The families of slugs and garden slugs

(*Limacidae, Agriolimacidae and Arionidae*)

Their body is always without a shell, slugs have their breathing hole in the rear part of the shield, garden slugs in the front part. The body is multi-coloured, often with longitudinal strips or spotted patterns. They produce slime helping them in movement and protecting their body against drying out. Not a lot of vermin leave such slimy track.

Together with frogs and mice, they are food for many owls. However, we find only a small, several-millimetre calcium plate from it in vomited remnants. Slugs are

also favourite delicacy for hedgehogs. In gardens, Leopard Slug (*Limax maximus*) and grey field slug (*Deroceras reticulatum*) are found most frequently.

They hide themselves in wet and permanently shaded places that are also used by them for hibernation. Natural enemies of slugs are any other marine gastropod eating their eggs, for example Spanish slug (*Arion vulgaris*). It got to our country at the beginning of the 1990s from Western Europe and basically it has no enemies in our country. However, the duck called "Beijing runner" is eager to eat this delicacy.





Common earthworm

(*Lumbricus terrestris*)

It is a segmented worm that can grow even up to 30 cm. In far Australia, it has a relative growing up to three metres! Its strength is hidden in its belt, like in the case of Jánošík – thanks to that it has the excellent regeneration ability.

When touching its body, we can feel fine hair and noticeable mucus helping it with breathing, moving and keeping the wet surface of the body. Thanks to mucus and the creeping movement, it has been successfully included in the category of vermin.

It feeds on leaves fallen off and small dead animals. Its function in creating humus, soil aeration and balancing

of the soil reaction (expressed with the value of pH) is irreplaceable. Earthworms loosen the soil up to depth of one meter, they fulfil an important task both in nature and agriculture. The number of earthworms is a guarantee of the high quality of soil. It does not like spraying and chemical fertilizers.



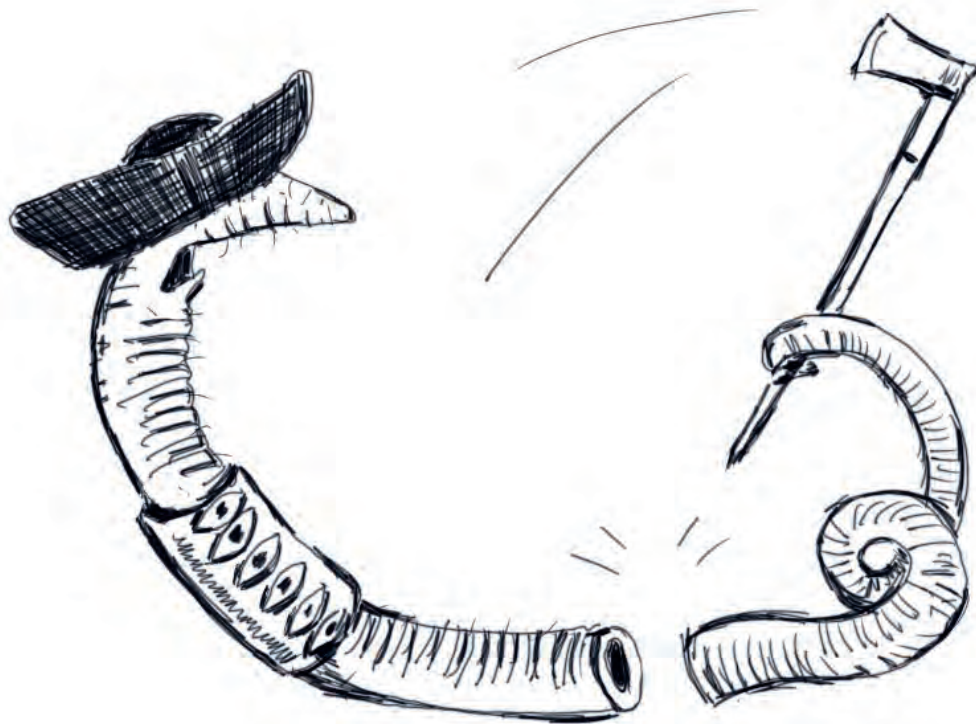

HEY THEY HEWED INTO ME LIKE INTO A STUMP IN THE TREES! HEHEY ...
(SLOVAK FOLK SONG - LITERAL TRANSLATION)

Order Spiders

(*Araneae*)

Only in Slovakia, we can find up to 1,000 various species! They have four pairs of legs, the body divided into their head-chest and abdomen. Spiders can see colours. In fact, originally they had six pairs of legs, but the first two legs have been transformed into biting legs that we call professionally *chelicerae* and *pedipalps*.

They are master acrobats on tightropes that some species create by means of spinning glands (spinnerets) on their bottom. Hunting of preys by means of networks is a really fascinating method of finding food that has inspired many legends and tales over thousands of years. A smaller network with the diameter of around 20 centimetres requires around 10 metres of the spider fibre, and it takes approximately an hour for the spider to create it.

The fibre is admirably firm and flexible, it is able to enlarge its dimension by up to 200%. Spiders have extra-body digestion. To demonstrate that they are dangerous to trifle with, they have often warning colouring. However, there is no need to be afraid of our spiders. They do not do any harm to people and they even bring good luck. Even if spiders are not pleasant for us, their presence in our houses should be welcomed as they rid us of flying insect.

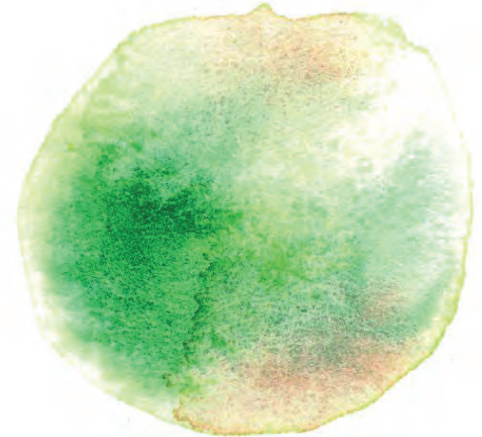

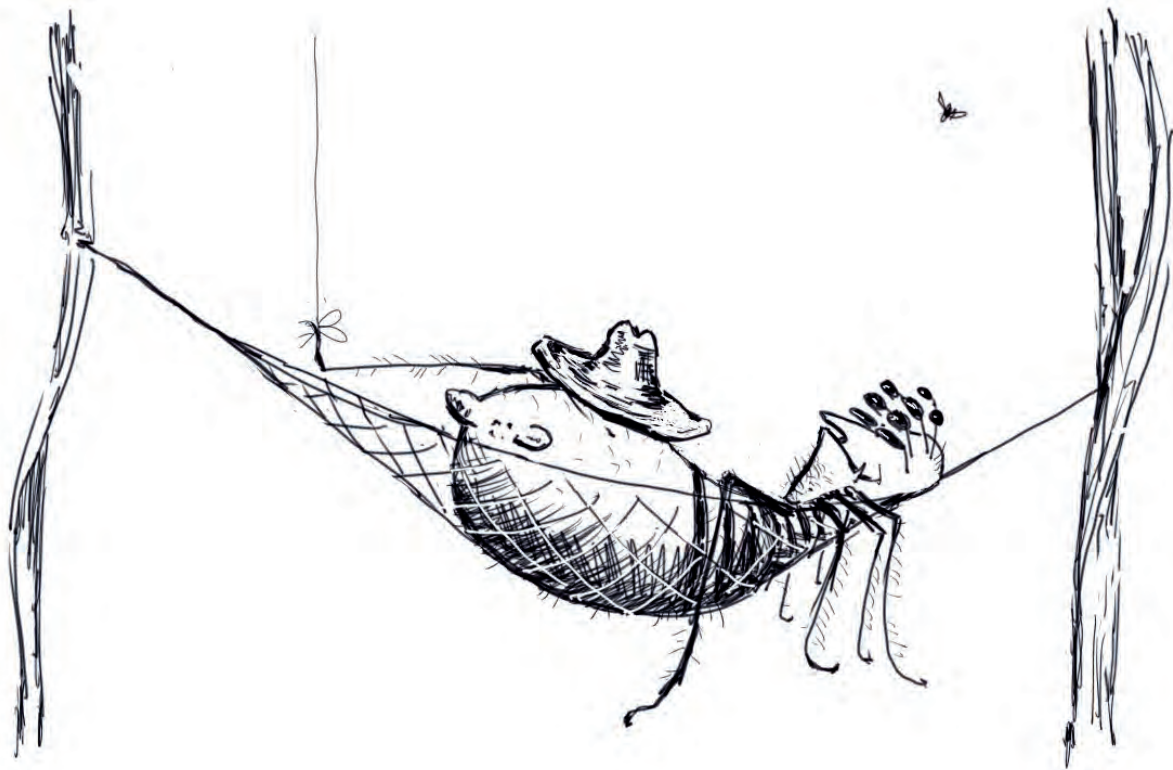

Common rough woodlouse

(*Porcellio scaber*)

Rough woodlouse is not insect, it is included among bark beetles – Isopoda. These are the only bark beetles that have succeeded in getting into the dry land. Rough woodlouses have seven pairs of extremities and feelers on their heads. They live in wet places, under stones, bark, in rotten trunks, or in humus. They hide themselves against light, they are night animals. Their body is covered with a thick skin (*cuticle*) containing calcium carbonate.

In fact, rough woodlouse is such small armoured vehicle. If you touch them, they curl up into a firm small ball and remain motionless for several seconds. Rou-

gh woodlouse is very useful. It lives on remnants of plants, thus speeding up their decomposition.

Larvae hatch out in the cavity under the abdomen filled with liquid and they remain there for several weeks. Rough woodlouse live for two to three years and they are often preys of toads, lizards, or some spiders. Under one stone, we can often find various species of rough woodlouses together.



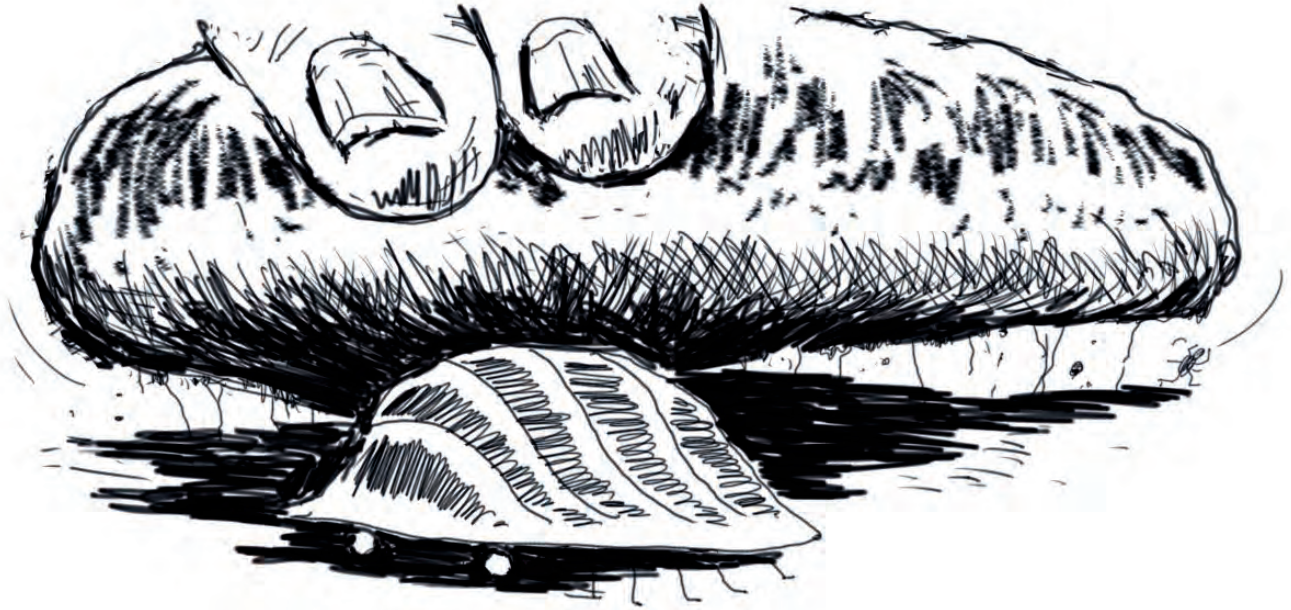

HE WHO IS WITHOUT SIN, CAN CAST THE FIRST STONE. BUT SEE WHAT
IS UNDERNEATH FIRST!

Common earwig

(*Forficula auricularia*)

It is one of several thousand species of earwigs. Many myths and superstitions have been woven round this representative of insect with imperfect transformation. It is true that it likes wet and shaded places, but it does not certainly crawl into our ear to enjoy biting through our eardrum.

This old myth is ingrained deeply in the awareness of people. It comes from the times when people did not know much more about earwigs than that they creep out of ears of dead people. It is a clumsy flyer and excellent biologic protector of fruit orchards. The thing is that its food includes small louses and larvae of various pest.

It is active mainly at night. Tongs at its bottom are not even able to cope with the skin on the apple. Therefore,

if it wants to enjoy sweet pulp, it must wait for hornet or wasp until they “start” an apple for it. So how it could deal with our eardrum?

In fact, the relation between ear and earwig has really existed. In the natural healing, they used dried and crushed earwigs as a drug against ear problems.



EARS

„ATTRACT“

EARWIGS?



And as talent is hereditary, we can look forward to new small virtuosos a year later playing during hot summer evenings.

Field cricket

(*Gryllus campestris*)

It is the biggest from our crickets. It lives mainly on warmed sand hillsides in underground holes, while both genders live in separated corridors. Males sit in front of corridors during summer nights and twitter by means of front membranous wings – they try to attract females. Therefore, they are also clothed in elegant glossy black tails.

They also react very sensitively to minor land trembles. They know very well when we walk about a meadow and they hide themselves quickly. They feed on arthropods and plant food. Females lay a relatively big number of eggs into underground holes from which larvae hatch out that hibernate in the underground.



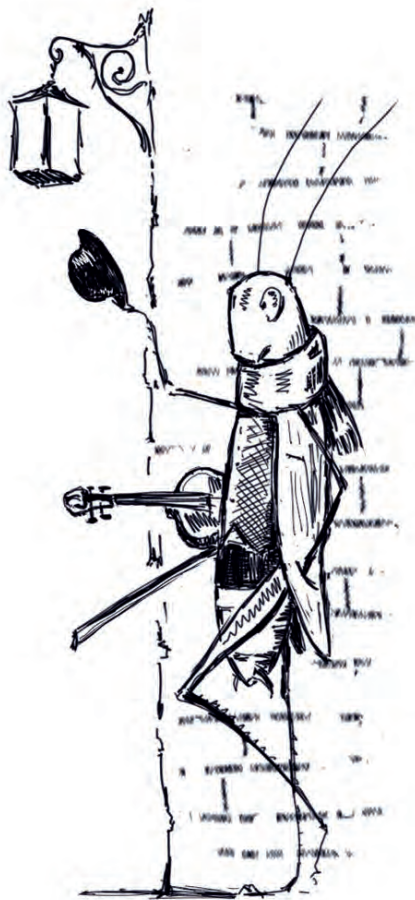

European mole cricket

(Gryllotalpa gryllotalpa)

This terrifying vermin has an elongated body and legs adapted for burrowing – it is perfectly adapted for life under the ground. It is not selective about food, it is a typical omnivorous animal. It often damages roots of plants due to which gardeners do not like it much.

At night, it comes out above the ground, it is also able to fly and it emits long chirping sounds, similar to chirping of green toad. Mole cricket is a cannibal. Females take care of eggs and larvae in their underground nests and it leaves the nest after having shed twice. They dig out nests for their eggs in loose soil and reinforce walls with their saliva. Under our conditions, their development takes two years.

In the past, mole cricket was abundant in gardens, today we can see or hear it only rarely. Mature individuals are welcomed food for our most beautiful, but also the smelliest bird – hoopoes.

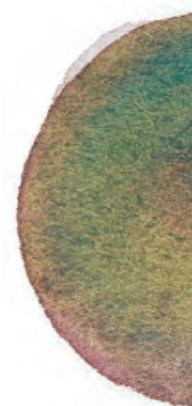

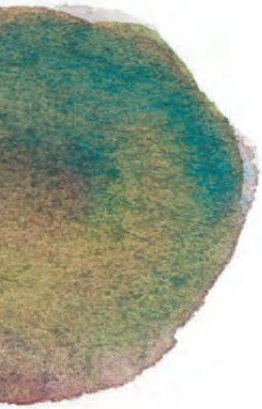

True bugs

(Heteroptera)

They are usually multi-coloured – they are characterized by *mimesis* (the protective colouring or behaviour imitating another, dangerous or poisonous animal). In nature, a combination of the red or yellow colours together with the black colour means warning: Be careful, I am poisonous! The head is concluded with a trunk with a mouth stinking – sucking organ.

True bugs mainly like plant juices, some of them do not mind blood of warm-blooded animals either. In addition to compound eyes, they also have crown small eyes. They are perfectly adapted either for swimming and digging or they excel at jumping.

The most of them can be found in the tropical and subtropical regions. Scientists have already described

more than 30,000 various species! There are around 1,000 of them living in Europe. They enjoy a company of others of their species. Our true bugs often like limes or carrot plants.

This vermin can really smell badly – it has glands on its back-chest producing a smelling liquid secretion.





Family Mosquito

(Culicidae)

Mosquito is able to cover up to 10 kilometres overnight and it can fly up to four hours without interruption at the speed of 1 to 2 kilometres per hour. Most species are active and are looking for food at night, evening, or morning. Mosquito emits a whistling tone in summer made up by trembling of wings and also of "vocal cords" that are stretched in chest pores.

All mosquito feed on nectar, but females are able to bother us very much by sucking our blood (it is professionally called hematophagy). Females need blood immediately after mating with males, during their flight and being very short. Then females lay eggs on the surface of stagnant waters. A shallow pool is fully sufficient for them originated in mud after a car crossed the place. A larva hatches out from an egg

that pupates after some time, and a young mosquito flies out from it prepared to repeat again the whole life cycle. Larvae of mosquito have a lot of enemies in their natural environment (water birds, fish, predatory larvae of diving beetles, dragonflies, or true bugs). Mature mosquito is food for many animals (bats, insectivorous birds, etc.).

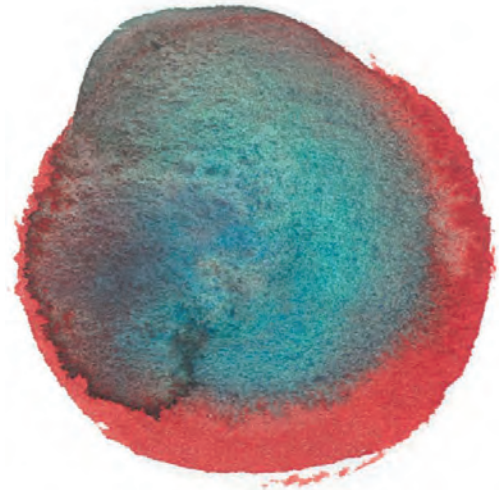

„BZZBZZBZZZ (NO! I AM A VEGETERIAN!)“



Common wasp

(*Vespula vulgaris*) and

German wasp

(*Vespula germanica*)

There are more than 10,000 species of wasps in the world, varying with their colouring, shape, size and way of life. Mature wasps are omnivorous animals – they feed on nectar, fruit, but they also chase after pests, for example small louses, flies, worms.

Larvae are carnivorous. Wasps are main pollinators of plants. They build their nests from chewed wood that they mix with saliva. Unlike bee, wasp is able to sting more times without hurting itself. Its sting is straight, smooth, and it is not concluded with an anti-tip like a harpoon.

Our advice:



It is useless to try to defend against wasps with hysteric waving; non-aggressive species get scared and sting you in their defence. Aggressive wasps sting you anyway, and more furiously.



If an aggressive wasp attacks you, try to leave the place as soon as possible before it attracts any other wasps with its aggressive pheromones.



If you engage the attention of any wasp or if you are even to its taste, you do not have to be afraid of being stung immediately. You can only feel its “small tongue” with which it tastes your skin, or licks sweat or remnants of food that have left on your hands. In any case, never panic, as your swift movements only provoke it for their defence.



THE WINE HAS NOT LEAVENED YET
BOYS LETS ' DRINK IT!
(SLOVAK FOLK SONG - LITERAL TRANSLATION)



Genus Digger wasp

(*Ammophila*)

The digger wasp belongs to insect living in solitude. When moving, vibration of their bottom is typical of it. The name of digger wasps is derived from behaviour of females that are able to dig out corridors in the ground for their offspring. For their larvae they hunt live prey that they paralyse with exact pricking of their sting in the nervous node and they drag it away to their prepared small corridor or chamber. However, they never kill it as they need it fresh, they lay eggs on it and larvae use the paralysed prey as food.

The digger wasp loves the sunny and hot environment. Females – mothers are very caring. It lets each of its eggs to have one nutritious caterpillar. After laying an egg, they close the small chamber well with sand or clay. It is a frequent occupant of insect hotels.

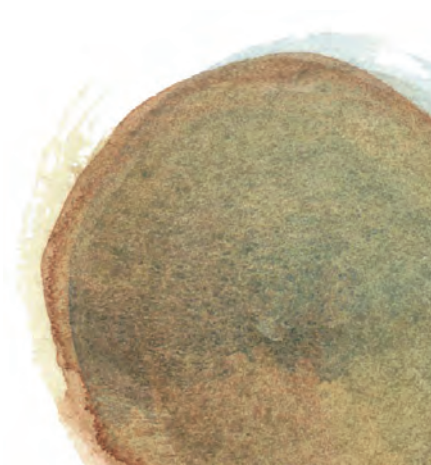

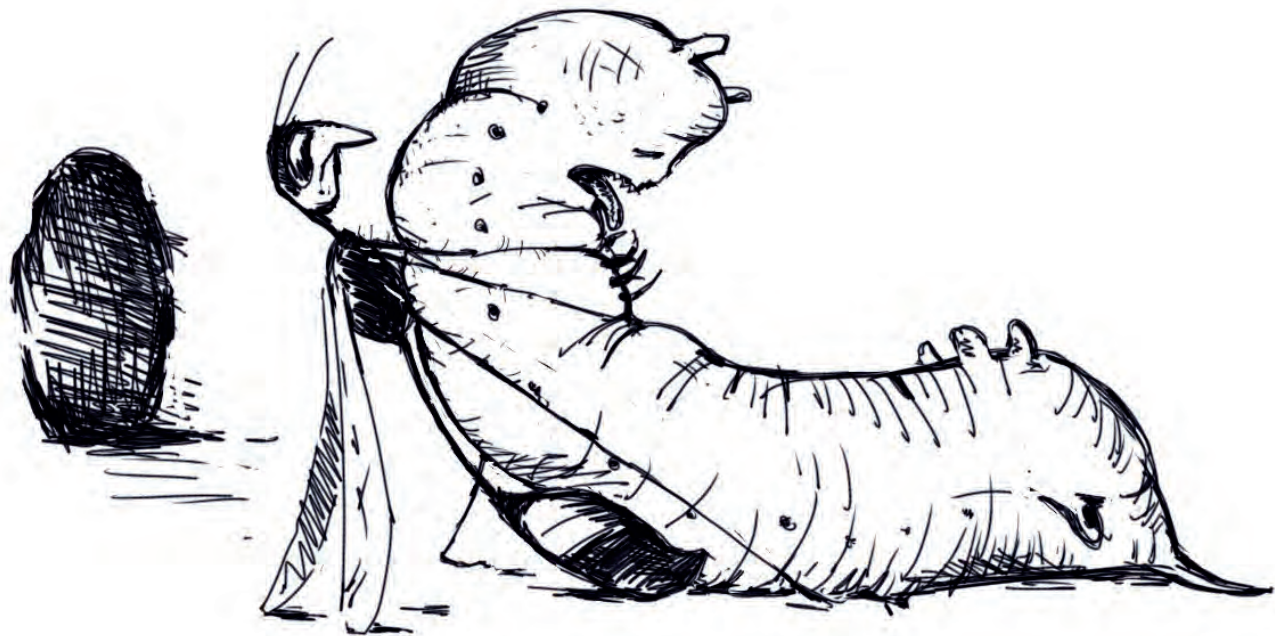

Asian ladybeetle

(*Harmonia axyridis*)

It appeared in 2008, it comes from Eastern Asia. It is very voracious, in addition to small louses it also hunts any other insect and its development stages. It also eats eggs and larvae of our original ladybeetles. In autumn, when there is less animal food, it also improves its menu with fruit juices. Originally, it was used as the biologic protection in greenhouses as it likes small louses, another insect, and pollen.

During its life, it produces up to 2,000 eggs and in Slovakia it is one of the so-called invasive species of animals.

In its original homeland it seeks rocks with slits and tall trees, therefore it flies instinctively into tall light items (houses, human dwellings). While being in danger, it

defends itself with a yellow drop of stinking liquid and it can also bite. As if we do not have our own vermin enough!

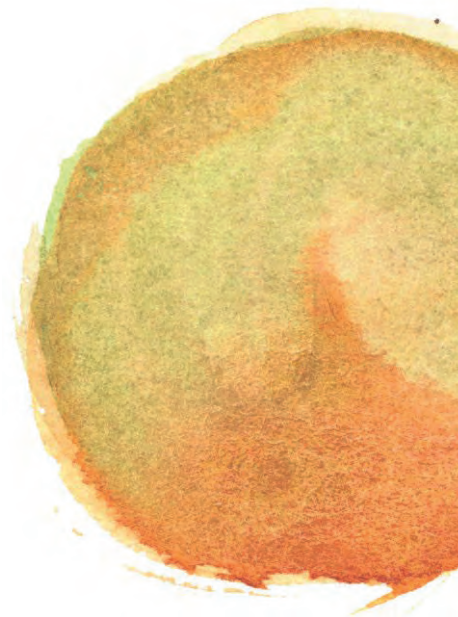

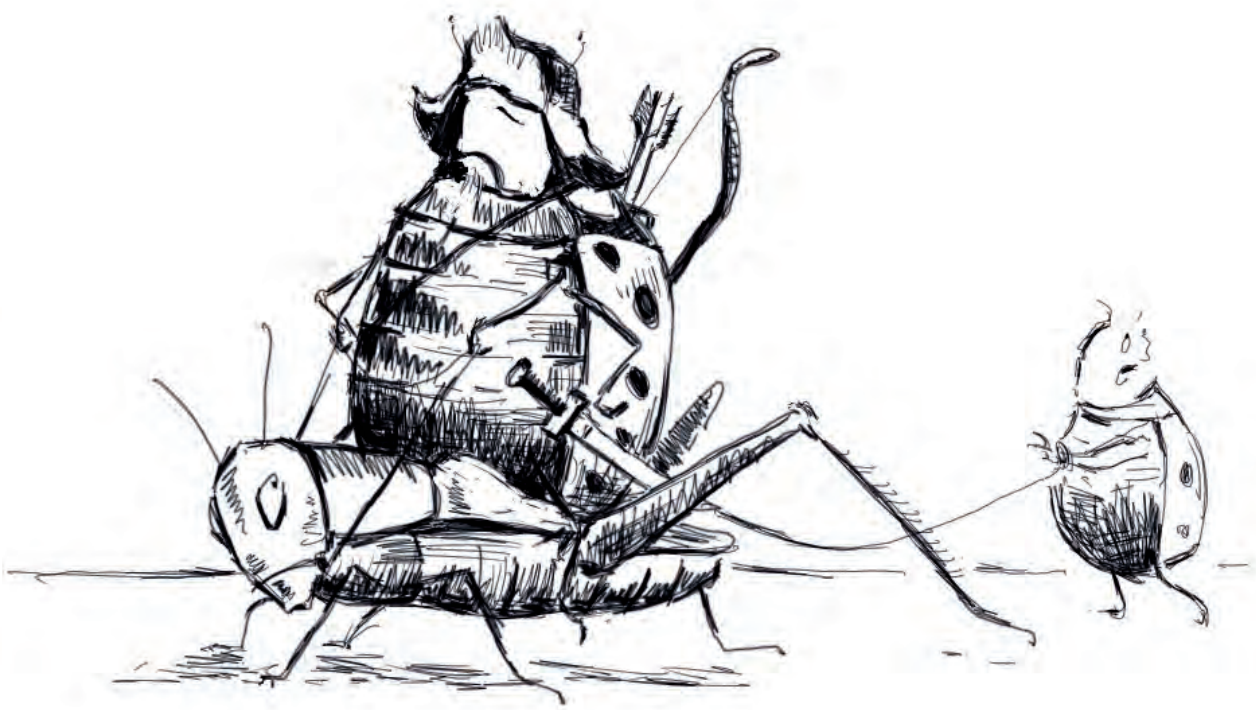

Common cockchafer

(Melolontha melolontha)

Its wing-cases have the chocolate-brown colour. You may say to yourselves – yum! But you would not certainly like it. Once cockchafers were abundant. During summer nights they were flying around street lamps. Today, however, their occurrence is really rare due to the use of pesticides.

Females bury up to 80 eggs at depth of 10 – 20 cm into the soil. In 4 – 6 weeks, larvae (grubs) start hatching out from them that are active only in spring and summer. In the winter months, they hibernate 20 – 100 cm under the surface of the ground. They live in the ground for 4 to 5 years until they grow to the size of 4 – 5 cm.

They like compost sides and heaps of organic materials. They pupate in autumn and a mature cockchafer comes out at the end of April or May. They mate nearly immediately and in two weeks females lay eggs.

Larvae under the ground – grubs are voracious and farmers mainly consider them to be a real disaster. On the contrary, mole loves them eating!





Genus Toads

(*Bufo*)

Toads are typical terrestrial frogs seeking water only for their reproduction. They can endure heat and dryness better than most people think. In Slovakia, two of three representatives of the genus *Bufo* are living: common European toad (*Bufo bufo*) and European green toad (*Bufo viridis*).

Behind their eyes, toads have grouped toxic (*parotid*) glands. Their excreted remnants played an important role in various witch infusions. An inexperienced dog that takes a toad in its snout will definitely remember that it should not annoy it in the future any more.

The power to forecast weather was attributed to frogs, various parts of its body were used in the natural healing, in fortune-telling, for the protection, but also

for ensuring a good deal. It is interesting that the green tree frog (*Hyla arborea*) enjoyed the general respect and the toad was considered to be the reincarnation of witch or devil. Except for the period of mating, they are active only at night. They feed on insect, slugs, and spiders.

So that the frog could grow, it sheds its old skin regularly. Toads live relatively long, up to nine years, captive frogs live to the age of about 35 years.

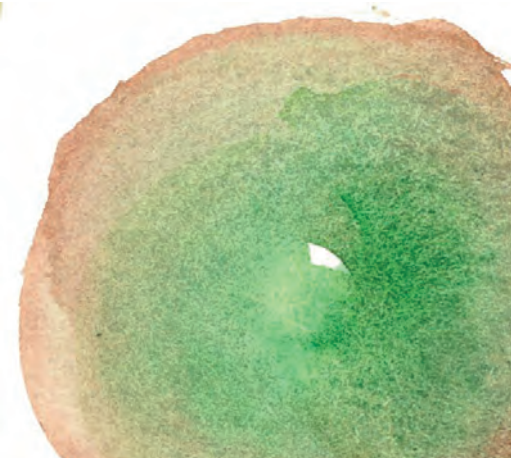



Blind worm

(*Anguis fragilis*)

It is one of legless lizard. In case of danger it can break off a part of its tail that can move for some time afterwards (this term is professionally called autotomy). The blind worm's tail grows partially back in a couple of weeks, but it remains smaller.

Blind worms have teeth bent backwards so they are able to grasp slippery food better, e.g. earthworms or slugs. It can replace its teeth.

If it has enough food (earthworms, slugs, arthropod, larvae), we can attract blind worms by heaps of stones and branches where it likes bathing in the sunshine. It has a lot of enemies, for example cats, martens, or raven birds.

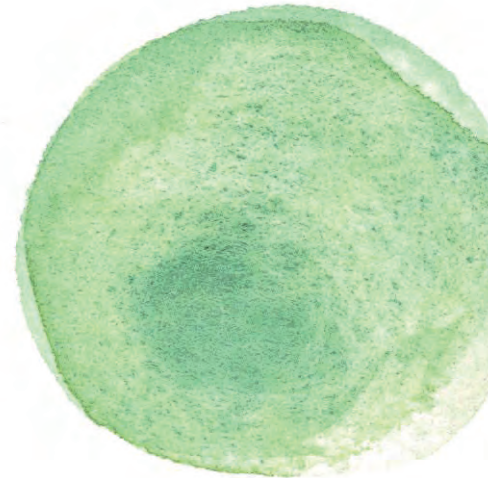



Genus Pigeons

(*Columba*)

It is true that pigeons' nests are not as perfect as nests of some songbirds. In addition, pigeons in towns are real vermin for many people. They foul statues, buildings and transmit illnesses. It is a vicious circle. People feed them because they like them, but at the same time they are annoyed that pigeons foul historical buildings or bald heads of passers-by with their droppings.

Epithelium of males' and females' goitre produces "goitre milk", with which parents feed their babies. It is milky mash made up by peeled *epithelial* cells of the goitre epithelium. The way of drinking is characteristic of pigeons. The pigeon stuffs its beak into water and sucks it rhythmically by narrowing and extending its gauntlet.



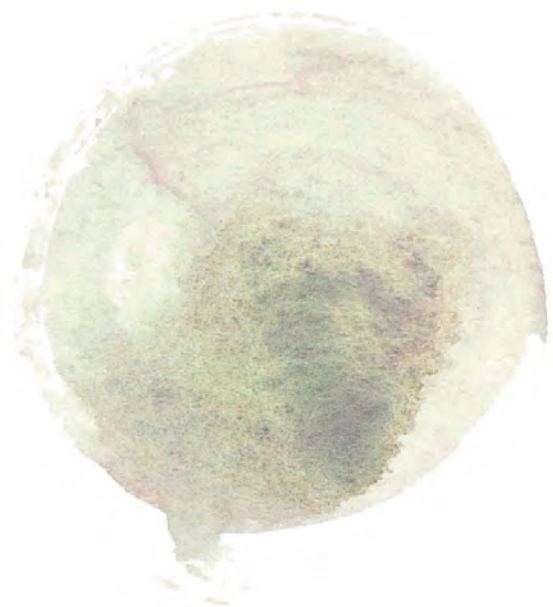

European mole

(*Talpa europaea*)

It lives under the ground where it digs corridors. In extended small chambers, it has its stocks of food that uses during unfavourable periods. In order to maintain food fresh, the mole does not kill it immediately. It injures its nervous system so that it remains paralysed, but alive. The mole comes out above the surface only rarely. It consumes 1.5 times more food than it weighs. One mole eats 36 kg of animal food per year. Its snout is not only a smelling, but also touching organ.

The mole is active both during day and at night all over the year, it does not hibernate. It contributes considerably against overpopulation of pests under the ground and aerates soil. The system of its small corridors can be up to 800 metres long. It pushes any

excessive clay above the surface, thus creating the known molehills.

Under an especially large molehill there is usually a nest, softly lined with leaves, grass and moss. Many gardeners are angry that moles destroy their lawns. However, just molehills can be a great place for sewing a mixture of meadow flowers!

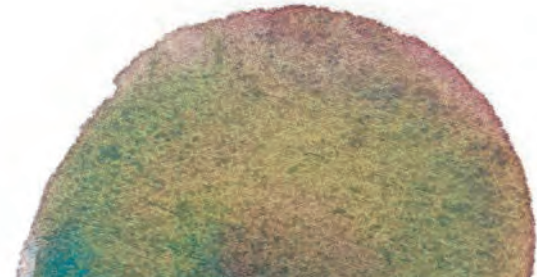

FREDDY THE MOLE - A NIGHTMARE
ON UNDERGROUND STREET



Order Bats

(Chiroptera)

There are 28 species of bats living in Slovakia. From time immemorial, people used to attribute to them various secret characteristics due to their appearance. Unfortunately, mostly negative – still in the recent past bats were considered to be the devil's companions, etc. Many people believe that they become entangled into hair, briefly indeed the real vermin.

Bats are our only flying mammals. Young animals are born in spring and suck breast milk. Our species are insectivorous, some of their relatives love fruit.

The so-called echolocation serves them for getting oriented at dark. They emit ultrasound signals by mouth and nose and then, after being rebounded from an object, they catch them with large ears. Thanks to

it, they can also fly at complete darkness. Immediately after covering their ears, bats are lost.

In addition to their excellent hearing, they also use their eyes for getting oriented with which it can also see at dusk well.

Bats are extremely important – they catch a large amount of night insect. The common bat catches around 70 pieces of various insect during night, up to 2.5 kg during summer. The water bat picks up 3,000 – 4,000 pieces of larvae of mosquito from the water surface during night.

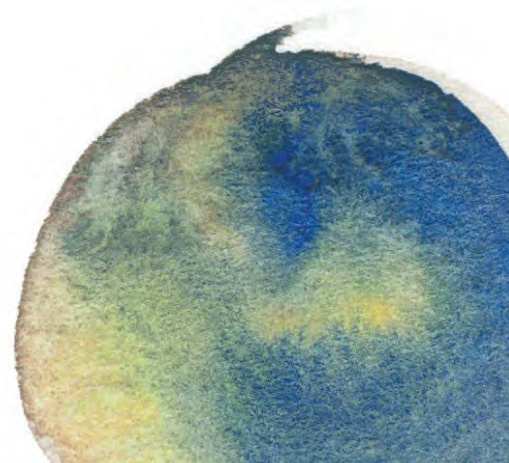



Feeling map

Maps have the huge power to present space information in an understandable and wide-acceptable form. If we also create the feeling map both before and after change implementation, we can determine the impact of changes made on pupils. We have learnt much about our school premises. However, how do we feel at the school courtyard?

Do we have our favourite places here? Places where we can not only play or relax, but also learn something? What feelings do murmuring of leaves evoke in you? Aroma of thyme? Twittering of small birds?

However, what about buzzing of flies? Raking of leaves? Stinging by mosquito? Damn it, but it itches...

How to draw up the feeling map:

 We need a large (format A2 – A0) paper with the school premises plotted.

 Let us determine what everything we want to find out about our school premises. For example:

- places I like, ugly places, - places, with occurrence of vermin, - places where vermin could move to,
- places where I worked the hardest, - places where I like spending my leisure time, - places where I am proud of my school.

 Let us mark each category we search for unambiguously with a colour or symbol selected in advance.

 Let us try to identify specific places, we are allowed to mark maximum two places in one category, unless it is defined otherwise.

 Everybody marks places according to their feelings. This activity requires longer time and it is not good to perform it in a limited time and together.

 We can process the result graphically into the feeling map of the school premises.



**What new have we learnt about the school?
Which places are students proud of and which ones they do not like?**

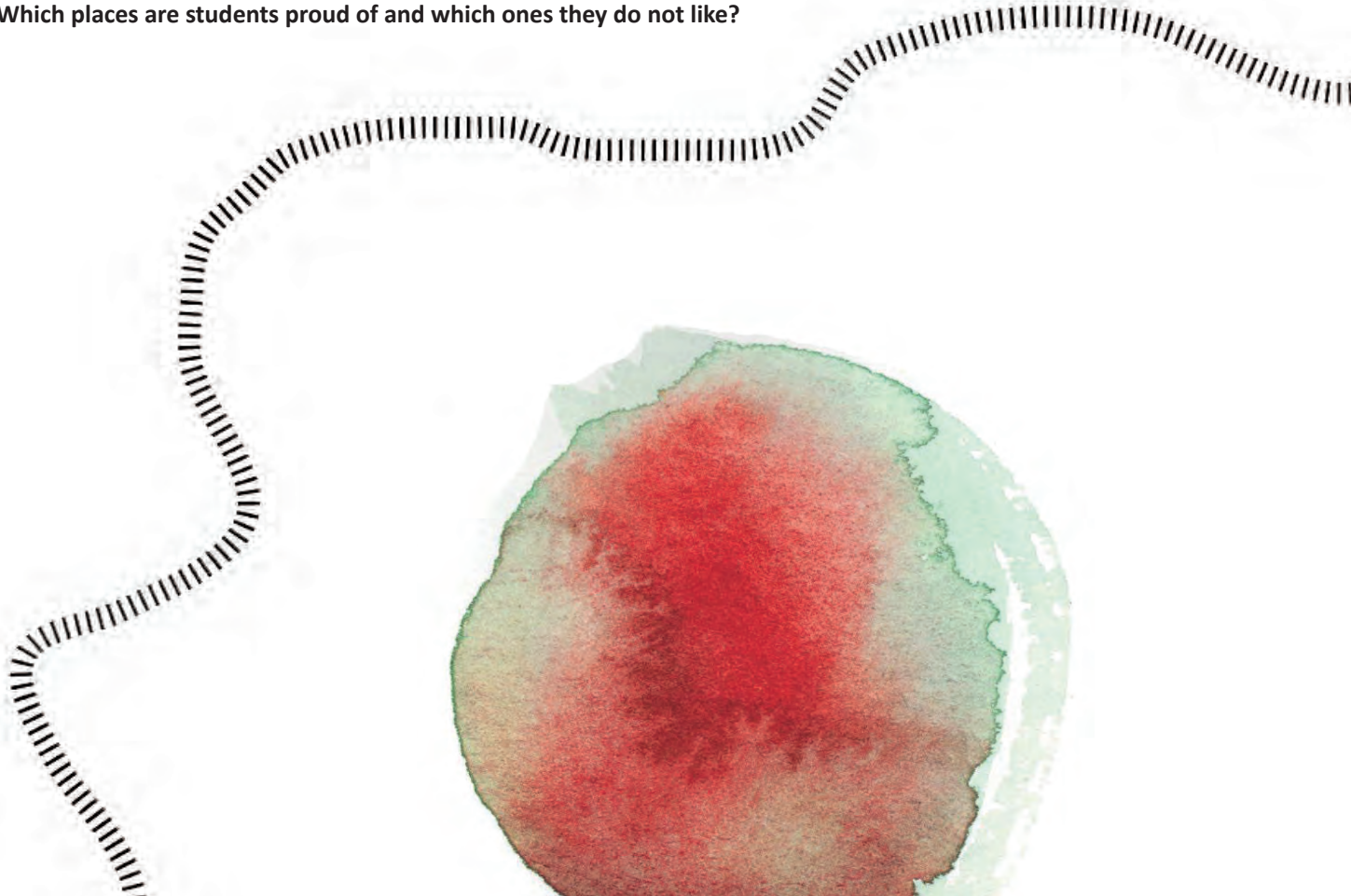

Conclusion

We believe that we have also convinced you with this manual that vermin is very important for the Ostrovné lúky, and not only for them.

Vermin is an important part of food chains. It reacts quickly to changes in the environment, therefore it is a good indicator of their changes. It means that it signalizes to us with its occurrence (or reduction) what is happening in the landscape. For example, the more species of birds is living in the given landscape, the better.

Because in such case we know that:

 we live in a varied, mosaic, healthy landscape of the Lower Rye Island (Dolný Žitný ostrov);

 windbreaks, hedgehogs and ridges are again

growing here and a fine network of relations is functioning here with a sufficient number of places for nesting;

 pastures and areas near the rivers of Čalovecký Dudváh and Částa are again grazed;

 old head willows near the river of Čalovecký Dudváh have been preserved;

 water and wetlands are a suitable place for life;

 a sufficient amount of suitable vermin can certainly be found here.

Everybody would probably like living in such varied and interesting landscape. And we are sure that one can live well in such pleasant landscape.

If you have implemented just only one idea from this manual, you have already contributed positively within your bounds of possibilities to the environmental protection.

We believe firmly that your liking will only be increasing.

Vermin team



We like vermin!

We at BROZ (Regional Association for Nature Conservation) really like vermin! Therefore, we actively renew places for it to live, either meadows, pastures, forests, rivers, or wetlands. Where? Mainly in southern and western Slovakia, also just in Bratislava and its surroundings.

We at the Slovak Environment Agency (SAŽP) have also a very positive relation to vermin! At the Lower Rye Island at the Environmental Education Centre (SEV) of the Slovak Environment Agency (SAŽP) Dropie we teach how to produce insect small houses for vermin, we educate both students and teachers about it and help to implement ideas supporting vermin. We have also drawn up this manual for you about Secrets of Vermin.

We at the Water Research Institute mainly take care of water vermin. We examine, record and analyse it and then we create for it directly in the terrain a new wetland or river arm.

And we at the Faculty of Natural Sciences in Bratislava supervise it everything, we monitor vermin, examine it and write reports about it helping the other colleagues to find out what is necessary to do so that there is even more of such vermin!

And why do we do it everything? Vermin is an important food component for many species of birds. If we want to help birds, we also have to help vermin.



Contents

What is vermin?	4	Before we start	22
Special Protection Area Ostrovné lúky	6	Vermin house	22
Red-footed falcon	8	Mini vermin houses	24
Tawny pipit	10	Plant pot for earwigs	24
Lesser grey shrike	12	Nesting box for birds	25
Amiable landscape	14	Feeders and watering places for birds	27
Unpleasant landscape	16	Boxes for bats	28
What with it now?	18	Herb and perennial garden beds	30
Let us map before a change	19	Plant trees	32
Let us propose the plan of changes	20	How to do it	33
Let us consult our intentions with the school management, seek advice from experts	20	Please, familiarize yourselves	34
Let us implement changes and watch what will happen	21	The families of slugs and garden slugs	36
		Common earthworm	38
		Order Spiders	40
		Common rough woodlouse	42
		Common earwig	44

Field cricket	46
European mole cricket	48
True bugs	50
Family Mosquito	52
Common wasp, German wasp	54
Genus Digger wasp	56
Asian ladybeetle	58
Common cockchafer	60
Genus Toads	62
Blind worm	64
Genus Pigeons	66
European mole	68
Order Bats	70
Feeling map	72
Conclusion	74
We like vermin!	75

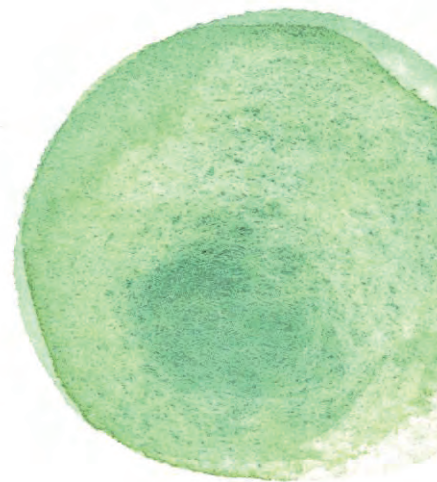



Notes

The Center of Environmental Education of the SEA Dropie can be found on the Lower Rye Island in the center of the Special Protected Area Ostrovné lúky. On the 6 hectare green island of biodiversity in the agricultural landscape, we offer environmental programs for a wide target group in SEV Dropie. More about our activities at <http://dropie.sazp.sk/> or FB SEV Dropie.

In cooperation with partners and volunteers, it also carries out environmental activities in the SPA Ostrovné lúky. Thanks to the joint project LIFE12-NAT / EN / 001155 Birds Protection in the SPA Ostrovné lúky, the first edition of the Handbook Secrets of Vermin was published.

More information about the project <https://broz.sk/projekty/ostrovnne-luky/>



SECRETS OF VERMIN

Text: Katarína Béresová (Vajliková), Ladislav Bíro

Review: Tomáš Čejka

Illustration and paintings: Ladislav Vojtuš

Design: Martina Ridzoňová, Mária Sklenárová

Translation: LEXMAN TE, s. r. o.

Published: Slovak Environment Agency

Pressed: DMC s. r. o., Nové Zámky

First edition

2021

ISBN: 978-80-89503-88-9



*The activity has been implemented within the framework of national project
Information and providing advice on improving the quality of environment in Slovakia.*

The project is cofinanced by Cohesion Fund of the EU under Operational programme Quality of Environment.

